



FROM IDEA TO PRODUCT

2026

CATALOGUE

**MINIDUMPERS
MINI EXCAVATORS
TRACTORS
UNDERCARRIAGES
SCREEN**



www.alcaeurope.com



Relationships are our driving force

Alca Europe was born from the combination of technical expertise, design and satisfaction in helping people work to the best of their ability. For years, we have treated your projects as if they were our own.

Reliability, integrity, empathy

Our work is based on simple but solid values: reliability, integrity and empathy. We believe in authentic relationships, transparency and listening to the needs of those who rely on us. Every machine we build resembles us: it is concrete, robust and made to last.

We are committed to offering solutions that not only work, but also become tools you can rely on every day.

That is why we focus on quality, continuous support and a direct relationship with our customers, who are first and foremost our partners.

We have years of experience, but we are as curious as we were on our first day

Our passion for innovation has always been our driving force in creating products that have tangible value for our customers.

We have always believed in the value of research and development, and in connecting with the workers who use our hydraulic machines.

These are the pillars of our work, which have allowed us to consolidate a range of versatile and practical products, designed to simplify hard work, from the field to the construction site.



Hydraulic machines **configurable** for professional work



Mini dumpers

Alca Europe offers a range of hydraulic tracked minidumpers ideal for use in narrow, muddy, stony and steeply sloping areas. The main feature is their multifunctionality: with the same machine, you can move, dig, level, shred, shovel, lift, transport, feed, drill and much more, simply by replacing an accessory. All this is achieved through hydraulic operation, which allows for precision, speed of movement and low ground pressure. Its compact size allows it to be used even inside homes. The standard equipment guarantees maximum safety at work.

The range consists of various models depending on the needs and type of user, with a load capacity ranging from 400 to 1,000 kg.

Features

- Powerful and reliable Honda and Yanmar engines
- Extremely reliable and precise hydraulic motors, equipped with high-capacity tapered roller bearings
- Intuitive and ergonomic controls to facilitate work
- High-viscosity "Agip" hydraulic oil to ensure operation at high and low temperatures
- High-quality rubber tracks; hardened cast steel drive wheel
- Robust and solid accessories
- Safety is paramount: the entire range is equipped with safety devices that immediately and automatically stop the vehicle. The parking brake is standard.

We urge operators to always use personal protective equipment.



The TC 400 is the perfect model for private individuals looking for ease of use and practicality, thanks to the hydraulics that also characterise the other models in the range.

It is particularly suitable for transporting equipment such as shredders, generators, etc., in agriculture and gardening.

It can be equipped with a tipper body or bucket, with manual tipping.



TECHNICAL SPECIFICATIONS

Operating capacity:	400 kg
Engine:	Honda GX200, 4-stroke single cylinder OHV petrol engine
Max power:	4,3 kW (5,8 HP)
Dimensions:	1109x650xH1086 mm
Hydraulic pumps:	1 gear pump
Transmission:	hydraulic
Speed:	1 speed, 0-2,8 km/h
Max inclination:	25° - 46%
Empty weight:	~ 200 kg
Track width:	180 mm
Hydraulic tipping:	No
Starting:	manual
Overcenter valves:	optional

ACCESSORIES

- Manual tipping body
- Manual tipping dumper

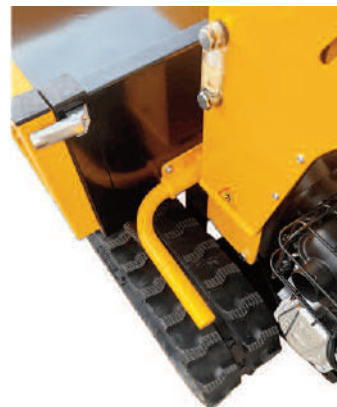

DIMENSIONS

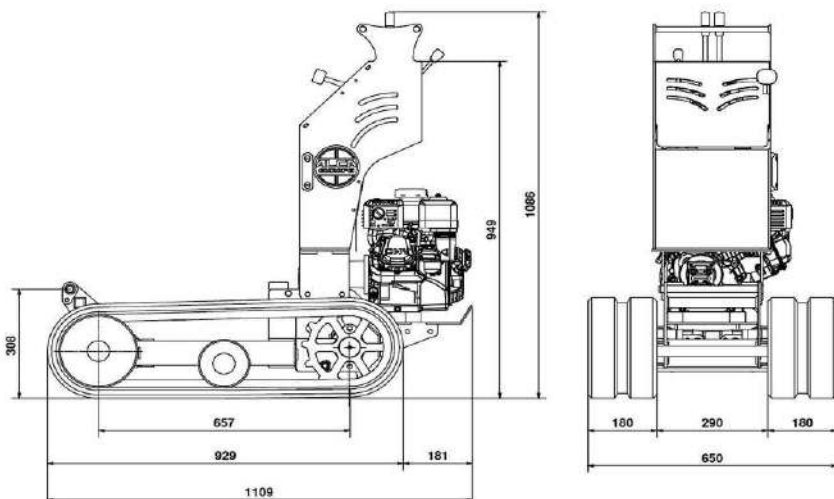

In order to improve the product, Alca Europe reserves the right to modify the characteristics without prior notice.

information



alcaeuropa.com

The TC 500 is a machine designed for small construction companies.

It allows you to load, unload and move materials quickly and safely thanks to its hydraulic drive, which halves working times compared to mechanical alternatives.

Its compactness, intuitiveness and ease of use, together with controls that guarantee a prompt response to commands, make it a pleasure to use.



TECHNICAL SPECIFICATIONS

Operating capacity:	500 kg
Engine:	Honda GX200, 4-stroke single cylinder OHV petrol engine
Max power:	4,3 kW (5,8 HP)
Dimensions:	1357x650xH1057 mm
Hydraulic pumps:	2 gear pumps
Transmission:	hydraulic
Speed:	1 speed, 0-2,8 km/h
Max inclination:	25° - 46%
Empty weight:	~ 275 kg
Track width:	180 mm
Hydraulic tipping:	standard
Starting:	manual
Overcenter valves:	optional

ACCESSORIES

- Dumper
- Dumper + shovel
- Front blade
- Body with openable and removable sides
- Body with extendable and removable sides
- Construction/agricultural body
- Mower
- Large dumpers
- Overcentre valves

DIMENSIONS

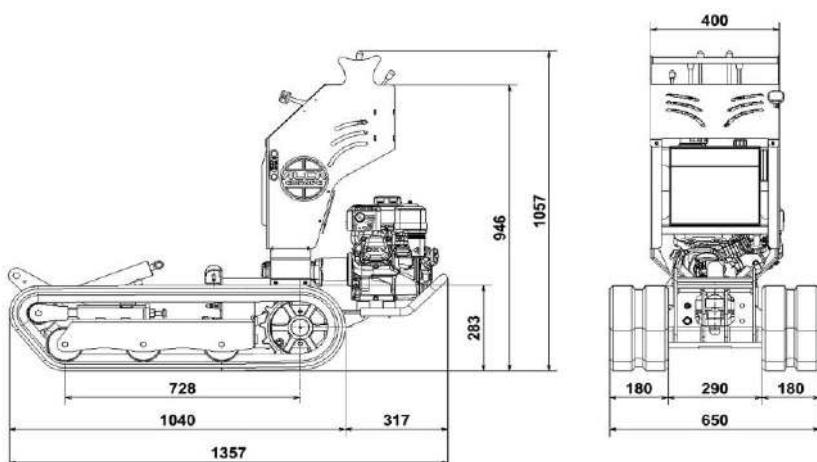

In order to improve the product, Alca Europe reserves the right to modify the characteristics without prior notice.

information



The TC 550 further expands on the capabilities of the previous model, with additional features that make this machine the most versatile and multifunctional product for construction applications and beyond.

In addition to the many applicable accessories, the TC 550 is equipped with dual speed:

- Working speed (suitable for moving the machine and a power take-off)
- Transport speed (for moving material faster).

The ease with which accessories can be interchanged makes it a machine that performs at its best in many sectors.



TECHNICAL SPECIFICATIONS

Operating capacity:	500 kg
Engine:	Honda GX200, 4-stroke single cylinder OHV petrol engine
Max power:	4,3 kW (5,8 HP)
Dimensions:	1384x650xH1043 mm
Hydraulic pumps:	3 gear pumps
Transmission:	hydraulic
Speed:	2 speed: 0-2,3 km/h ; 0-3,7 km/h
Max inclination:	25° - 46%
Empty weight:	~ 320 kg
Track width:	180 mm
Hydraulic tipping:	standard
Starting:	manual
Overcenter valves:	standard

ACCESSORIES

- Dumper
- Dumper + shovel
- Front blade
- Sides that can be opened and removed
- Body with openable and removable sides
- Construction/agricultural body
- Mower
- Hydraulic PTO
- Large dumpers
- Lift
- Concrete mixer support legs
- 150-litre concrete mixer
- 150-litre concrete mixer + shovel

DIMENSIONS

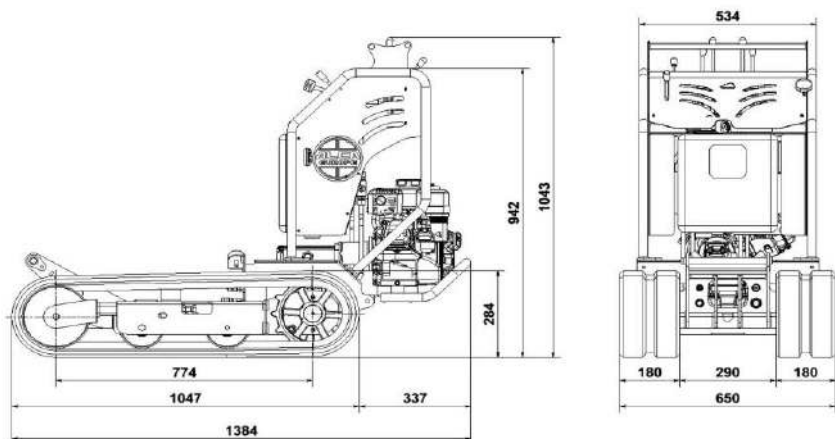

In order to improve the product, Alca Europe reserves the right to modify the characteristics without prior notice.

information



alcaeurope.com



TC650 ALPINE

The TC 650 is the ideal choice for transporting, loading and unloading construction materials, timber and much more in areas with steep slopes.

The model is also suitable for hire for work.

Even the basic version of the vehicle is equipped with longer tracks, a tilting roller and safety valves to ensure maximum safety when descending steep slopes.

The TC 650 relies on an extended support surface, a low centre of gravity and tilting to conquer even the steepest slopes.



TECHNICAL SPECIFICATIONS

Operating capacity:	600 kg
Engine:	Honda GX270, 4-stroke single cylinder OHV petrol engine
	Yanmar L70, 4-stroke single cylinder diesel engine
Max power:	6,3 kW (8,4 HP) - 4,9 Kw (6,6 HP)
Dimensions:	1509x700xH1043 mm
Hydraulic pumps:	3 gear pumps
Transmission:	hydraulic
Speed:	2 speed: 0-2,3 km/h ; 0-3,7 km/h
Max inclination:	25° - 46%
Empty weight:	~ 350 kg
Track width:	180 mm
Hydraulic tipping:	standard
Starting:	manual - electric optional
Overcenter valves:	standard
Operator platform:	standard

DIMENSIONS

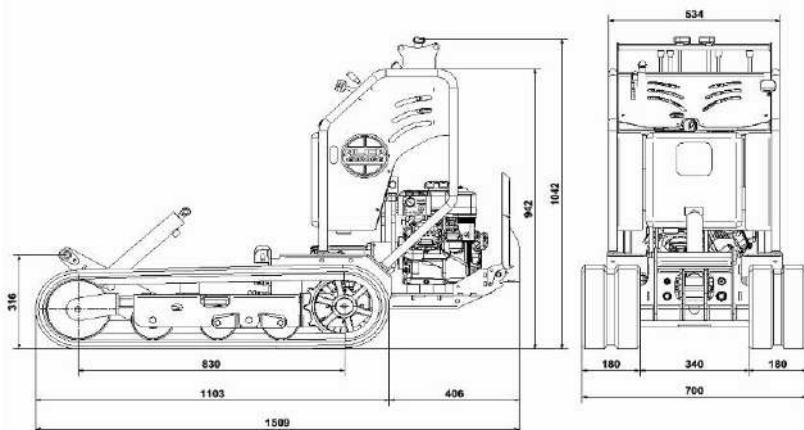

ACCESSORIES

- Front blade
- Sides that can be opened and removed
- Body with openable and removable sides
- Construction/agricultural body
- Mower
- Hydraulic PTO
- Large dumpers
- Dumper
- Dumper + shovel
- Lift
- 250-litre concrete mixer
- Concrete mixer + shovel 250LT
- Concrete mixer support legs
- 150-litre concrete mixer

In order to improve the product, Alca Europe reserves the right to modify the characteristics without prior notice.

information



The TC 750 is a product designed for advanced professional use. Supplied as standard with power take-offs for the use of various accessories, this machine's strength lies in its versatility.

The design and materials used are top of the range, providing the user with a complete and satisfying working experience.

The machine includes:

- Three pairs of quick couplings
- 9 HP petrol engine and 10 HP diesel engine
- Standard power take-offs

Optional: undercarriage extension →

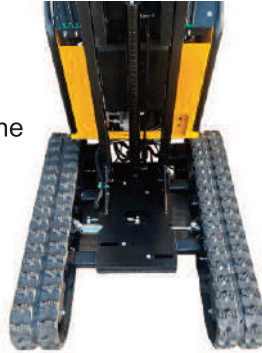

TECHNICAL SPECIFICATIONS

Operating capacity:	700 kg
Engine:	Honda GX270, 4-stroke single cylinder OHV petrol engine
	Yanmar L100, 4-stroke single cylinder diesel engine
Max power:	6,3 kW (8,4 HP) - 6,8 kW (9,1 HP)
Dimensions:	1468x700xH1221 mm
Hydraulic pumps:	3 gear pumps
Transmission:	hydraulic
Speed:	2 speed: 0-2,6 km/h ; 0-4,1 km/h
Max inclination:	25° - 46%
Empty weight:	~ 450 kg
Track width:	180 mm
Hydraulic tipping:	standard
Starting:	manual - electric optional
Overcenter valves:	standard
Variable width undercarriages:	optional
Operator platform:	standard

DIMENSIONS

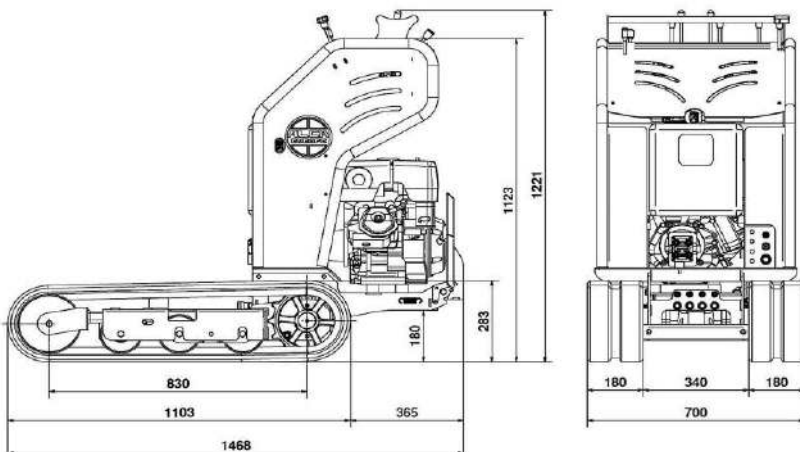

ACCESSORIES

- Front blade
- Body with opening and removable sides
- Body with extendable and removable sides
- Construction/agricultural body
- Mower
- Elevator
- 250-litre concrete mixer
- Concrete mixer + shovel 250LT
- Concrete mixer support legs
- Dumper
- Dumper + shovel
- Dumper + tilting shovel
- Chassis extension

In order to improve the product, Alca Europe reserves the right to modify the characteristics without prior notice.

information



alcaeuropa.com

The TC 850 is our model designed for construction professionals who need a machine that is sturdy and adaptable to the many challenges of the construction site.

This machine meets the needs of those who need to transport materials and work in confined spaces, on uneven and sloping terrain.

The TC 850 can be equipped with a variety of accessories:

- Dumper with tilting bucket for loading
- 300-litre capacity concrete mixer, self-loading via a special bucket
- Body with opening and removable sides
- Levelling blade
- Excavator



TECHNICAL SPECIFICATIONS

Operating capacity:	800 kg
Engine:	Honda GX390, 4-stroke single cylinder OHV petrol engine
	Yanmar L100, 4-stroke single cylinder diesel engine
Max power:	8,7 kW (11,7 HP) - 6,8 kW (9,1 HP)
Dimensions:	1571x780xH1286 mm
Hydraulic pumps:	3 gear pumps
Transmission:	hydraulic
Speed:	2 speed: 0-2,5 km/h ; 0-4,0 km/h
Max inclination:	25° - 46%
Empty weight:	~ 530 kg
Track width:	180 mm
Hydraulic tipping:	standard
Starting:	electric
Overcenter valves:	standard
Variable width undercarriages:	optional
Operator platform:	standard

ACCESSORIES

- Front blade
- Construction/agricultural bucket
- Mower
- Elevator
- Concrete mixer support legs
- 300-litre concrete mixer
- 300-litre concrete mixer + shovel
- Dumper
- Dumper + shovel
- Dumper + tilting shovel
- Chassis extension



DIMENSIONS

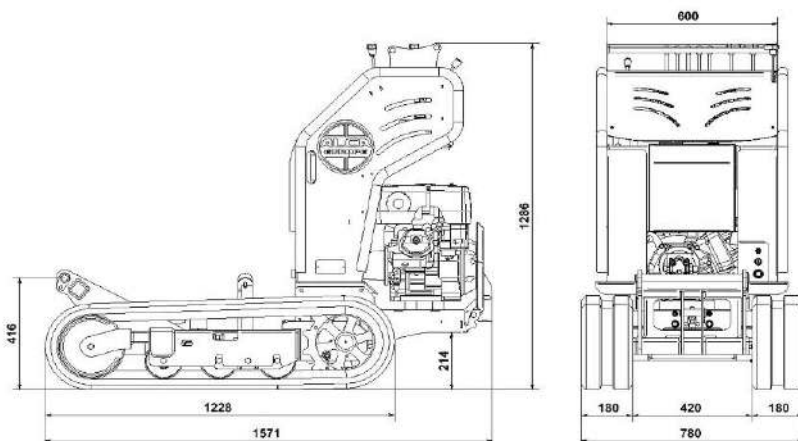



TC900

The TC 900 allows the operator to use all hydraulic lines simultaneously, thanks to the series distributor and the positioning of the control levers.

The use of the PTO in both first and second gear, the movement of the tracks, the loading of the shovel and the tipping of the dumper become faster operations, without downtime.

For these reasons, the TC 900 is a faster, higher-performance machine, with the same power and systems.



TECHNICAL SPECIFICATIONS

Operating capacity:	800 kg
Engine:	Honda GX390, 4-stroke single cylinder OHV petrol engine
	Yanmar L100, 4-stroke single cylinder diesel engine
Max power:	8,7 kW (11,7 HP) - 6,8 kW (9,1 HP)
Dimensions:	1571x780xH1286 mm
Hydraulic pumps:	3 gear pumps
Transmission:	hydraulic
Speed:	2 speed: 0-2,5 km/h ; 0-4,0 km/h
Max inclination:	25° - 46%
Empty weight:	~ 550 kg
Track width:	180 mm
Hydraulic tipping:	standard
Starting:	electric
Overcenter valves:	standard
Variable width undercarriages:	optional
Operator platform:	standard

DIMENSIONS

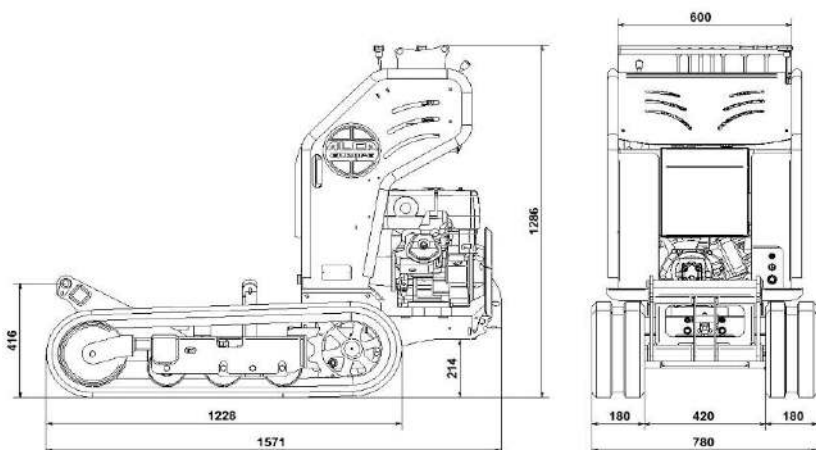

ACCESSORIES

- Front blade
- Construction/agricultural bucket
- Mower
- Lift
- Concrete mixer support legs
- 300-litre concrete mixer
- 300LT+ concrete mixer with shovel
- Dumper
- Dumper + shovel
- Dumper + tilting shovel
- Chassis extension

In order to improve the product, Alca Europe reserves the right to modify the characteristics without prior notice.

information

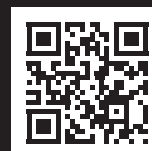

alcaeuropa.com

Exceed every limit.

The TC 1000 can dig, pile, level, transport and move any type of terrain. Thanks to its robustness, strength and size, it can reach places that other machines cannot.

Power is what characterises this model, making even the most difficult jobs easy. The self-loading and tilting shovel attached to the frame allows the TC 1000 to open up roads in hard-to-reach places.



TECHNICAL SPECIFICATIONS

Operating capacity:	1000 kg
Engine:	Honda GX390, 4-stroke single cylinder OHV petrol engine Yanmar L100, 4-stroke single cylinder diesel engine
Max power:	8,7 kW (11,7 HP) - 6,8 kW (9,1 HP)
Dimensions:	1646x910xH1341 mm
Hydraulic pumps:	3 gear pumps
Transmission:	hydraulic
Speed:	2 speed: 0-2,3 km/h ; 0-3,7 km/h
Max inclination:	25° - 46%
Empty weight:	~ 700 kg
Track width:	200 mm
Hydraulic tipping:	standard
Starting:	electric
Overcenter valves:	standard
Variable width undercarriages:	optional
Operator platform:	standard

ACCESSORIES

- Construction/agricultural bucket
- Concrete mixer support legs
- 500-litre concrete mixer
- 500-litre concrete mixer + shovel
- Dumper
- Dumper + tilting shovel
- Swivel fifth wheel for dumpers and concrete mixers

DIMENSIONS

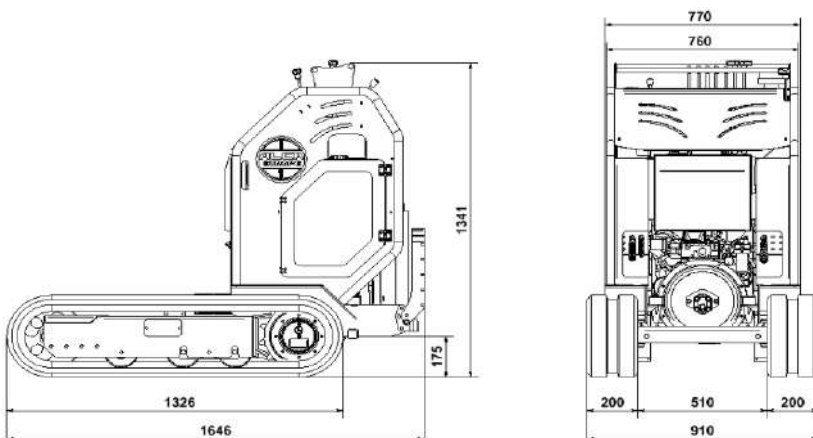

High-tip



**MULTIFUNCTIONAL
HIGH PERFORMANCE**

The TC 650H is the base model in the high-dump mini dumper range.

These variants are perfect for operators who have to manage more difficult loading/unloading operations directly onto high vehicles.

The forklift has been designed to lift material up to 150 cm in height, while its compact size allows it to get close to the vehicle and unload material comfortably and safely.

The machine is stable, thanks to a low centre of gravity, and combines strength, manoeuvrability and differentiated speeds.



TECHNICAL SPECIFICATIONS

Operating capacity:	600 kg
Engine:	Honda GX270, 4-stroke single cylinder OHV petrol engine
Max power:	6,3 kW (8,4 HP)
Dimensions:	1539x700xH1321 mm
Hydraulic pumps:	3 gear pumps
Transmission:	hydraulic
Speed:	2 speed: 0-2,3 km/h ; 0-3,7 km/h
Max inclination:	25° - 46%
Empty weight:	~ 350 kg
Track width:	180 mm
Hydraulic tipping:	standard
Max Lift Height:	1500 mm
Starting:	manual - electric optional
Overcenter valves:	standard
Operator platform:	standard

ACCESSORIES

- Front blade
- Body with opening and removable sides
- Body with extendable and removable sides
- Construction/agricultural body
- Mower
- Hydraulic PTO
- Large dumpers
- Dumper
- Dumper + shovel
- 250-litre concrete mixer (H max 80 cm)
- 250-litre concrete mixer + shovel
- Concrete mixer support legs
- 150-litre concrete mixer
- 150-litre concrete mixer + shovel
- 60 cm forks

DIMENSIONS

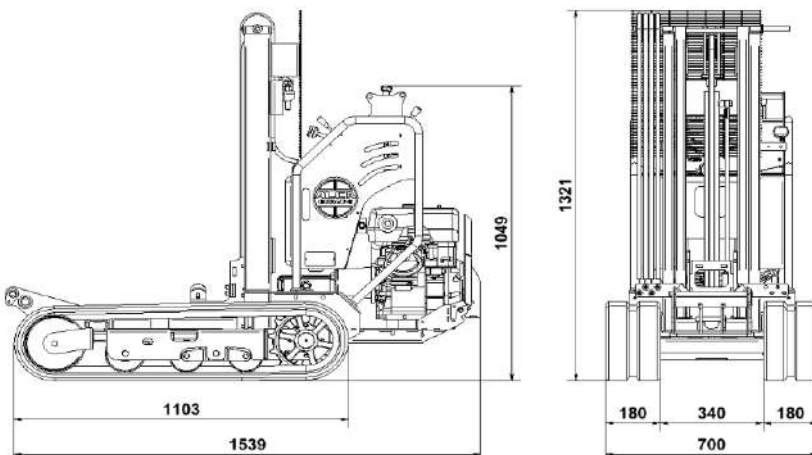

With its versatility, the TC 750H guarantees the operator fast working speeds in complete safety.

It is equipped with lifting and tipping lock valves, which allow the transport of heavier loads while maintaining the position set by the user. It can be fitted with a 150-litre concrete mixer with a discharge height of up to 1.5 metres, or a 250-litre mixer with a maximum discharge height of 80 cm.

The extendable carriage configuration makes the machine even more flexible and adaptable to any situation.



TECHNICAL SPECIFICATIONS

Operating capacity:	700 kg
Engine:	Honda GX270, 4-stroke single cylinder OHV petrol engine Yanmar L100, 4-stroke single cylinder diesel engine
Max power:	6,3 kW (8,4 HP) - 6,8 kW (9,1 HP)
Dimensions:	1578x750xH1310 mm
Hydraulic pumps:	3 gear pumps
Transmission:	hydraulic
Speed:	2 speed: 0-2,6 km/h ; 0-4,1 km/h
Max inclination:	25° - 46%
Empty weight:	~ 550 kg
Track width:	180 mm
Hydraulic tipping:	standard
Max Lift Height:	1500 mm
Starting:	manual - electric optional
Overcenter valves:	standard
Variable width undercarriages:	optional
Operator platform:	standard

DIMENSIONS

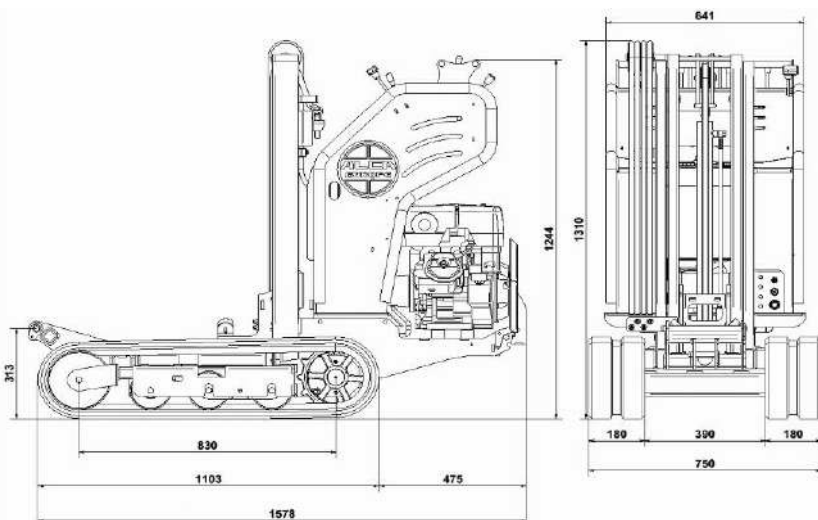

ACCESSORIES

- Front blade
- Body with opening and removable sides
- Extendable and removable sides
- Construction/agricultural body
- Mower
- 250-litre concrete mixer (H max 80 cm)
- Concrete mixer + Shovel 250LT
- Concrete mixer support legs
- 150-litre concrete mixer
- 150-litre concrete mixer + shovel
- Dumper
- Dumper + tilting shovel
- Chassis extension
- 60 cm forks

In order to improve the product, Alca Europe reserves the right to modify the characteristics without prior notice.

information

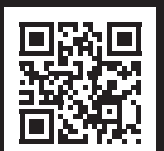

Powerful and professional, the TC 850H transports heavy loads effortlessly thanks to its solid frame and powerful engines.

The machine can be equipped with various accessories that allow for autonomous and efficient operation. The extendable boom configuration allows it to tackle all types of terrain, even the most sloping.

The 300-litre concrete mixer can reach a maximum discharge height of 80 cm from the ground, which is essential for the construction of kerbs and other building works.



TECHNICAL SPECIFICATIONS

Operating capacity:	800 kg
Engine:	Honda GX390, 4-stroke single cylinder OHV petrol engine Yanmar L100, 4-stroke single cylinder diesel engine
Max power:	8,7 kW (11,7 HP) - 6,8 kW (9,1 HP)
Dimensions:	1698x840xH1330 mm
Hydraulic pumps:	3 gear pumps
Transmission:	hydraulic
Speed:	2 speed: 0-2,5 km/h ; 0-4,0 km/h
Max inclination:	25° - 46%
Empty weight:	~ 750 kg
Track width:	180 mm
Hydraulic tipping:	Si
Max Lift Height:	1500 mm
Starting:	electric
Overcenter valves:	standard
Variable width undercarriages:	optional
Operator platform:	standard

DIMENSIONS

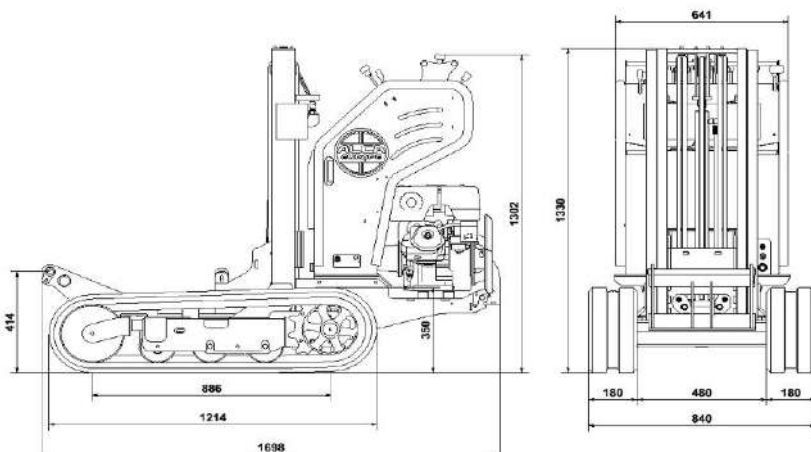

ACCESSORIES

- Front blade
- Construction/agricultural skip
- Mower
- Concrete mixer support legs
- 150-litre concrete mixer
- 150-litre concrete mixer + shovel
- 300-litre concrete mixer
- Concrete mixer + Shovel 300LT
- Dumper
- Dumper + shovel
- Dumper + tilting Shovel
- Chassis extension
- 60 cm forks



information



Combining movement and management of all uses at the same time is what sets the TC900H apart.

This machine, the top of the range in the H series, allows you to move around in complete freedom while keeping everything under control, so you don't waste a single minute on site.



TECHNICAL SPECIFICATIONS

Operating capacity:	800 kg
Engine:	Honda GX390, 4-stroke single cylinder OHV petrol engine Yanmar - L100, 4-stroke single cylinder diesel engine
Max power:	8,7 kW (11,7 HP) - 6,8 kW (9,1 HP)
Dimensions:	1698x840xH1330 mm
Hydraulic pumps:	3 gear pumps
Transmission:	hydraulic
Speed:	2 speed: 0-2,5 km/h ; 0-4,0 km/h
Max inclination:	25° - 46%
Empty weight:	~ 770 kg
Track width:	180 mm
Hydraulic tipping:	standard
Max Lift Height:	1500 mm
Starting:	electric
Overcenter valves:	standard
Variable width undercarriages:	optional
Operator platform:	standard

DIMENSIONS

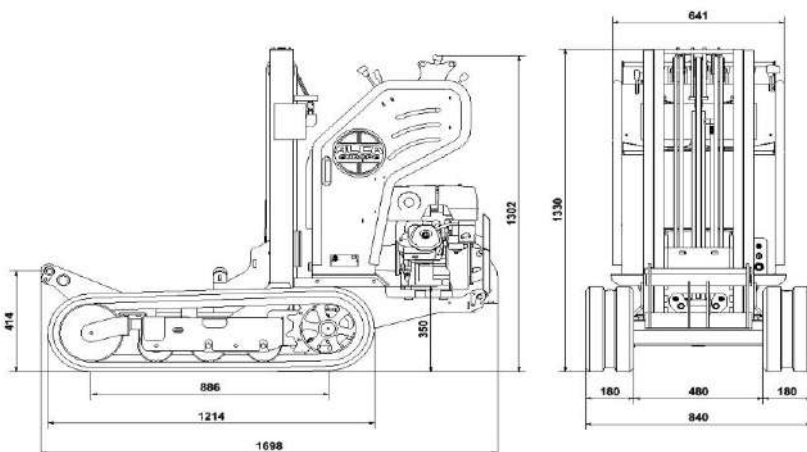

ACCESSORIES

- Front blade
- Construction/agricultural bucket
- Mower
- Concrete mixer support legs
- 150-litre concrete mixer
- Concrete mixer + Shovel 150LT
- 300-litre concrete mixer
- Concrete mixer + Shovel 300LT
- Dumper
- Dumper + shovel
- Dumper + tilting Shovel
- Chassis extension
- 60 cm forks

In order to improve the product, Alca Europe reserves the right to modify the characteristics without prior notice.

information



Mini dumper with two rear drive wheels and two front pivoting wheels. These features ensure a very low ground footprint, making it easy to use, especially in gardens and on delicate terrain.

Particularly suitable for gardening and landscaping, the TR500 can be equipped with a skip or dumper.



TECHNICAL SPECIFICATIONS

Operating capacity:	500kg
Engine:	Honda GX200, 4-stroke single cylinder OHV petrol engine
Max power:	4,3 kW (5,8 HP)
Dimensions:	1355x700xH1116 mm
Hydraulic pumps:	2 gear pumps
Transmission:	hydraulic
Speed:	1 speed, 0-4,2 km/h
Max inclination:	25° - 46%
Empty weight:	~ 225 kg
Track width:	16x6.50x8"
Hydraulic tipping:	standard
Starting:	manual

DIMENSIONS

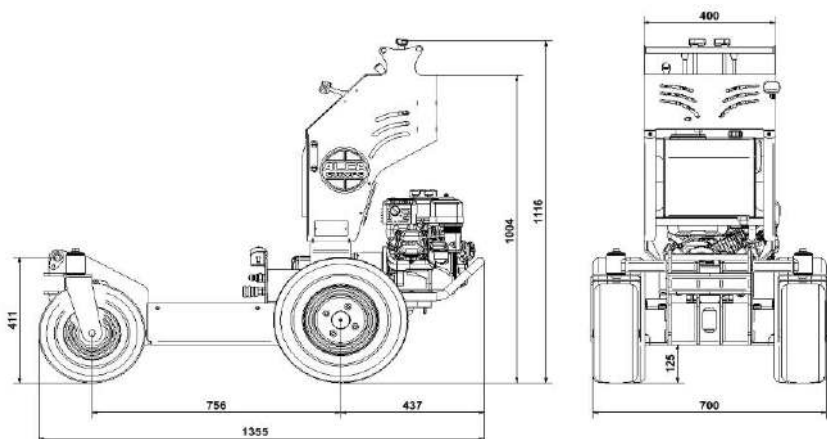

In order to improve the product, Alca Europe reserves the right to modify the characteristics without prior notice.

information





TR600

4x4

Speed of movement and transfer are the main qualities of this mini dumper.

The 4 wheels guarantee power and allow for minimal impact on the ground. It can be equipped with a dumper, self-loading shovel and skip. Suitable for complementary work in construction.



TECHNICAL SPECIFICATIONS

Operating capacity:	600 kg
Engine:	Honda GX200, 4-stroke single cylinder OHV petrol engine
	Honda GX270, 4-stroke single cylinder OHV petrol engine
Max power:	4,3 kW (5,8 HP) - 6,3 kW (8,4 HP)
Dimensions:	1422x700xH1065 mm
Hydraulic pumps:	3 gear pumps
Transmission:	hydraulic
Speed:	2 speed: 0-3,4 km/h ; 0-5,5 km/h
Max inclination:	25° - 46%
Empty weight:	~ 275 kg
Track width:	16x6.50x8"
Hydraulic tipping:	standard
Starting:	manual

DIMENSIONS

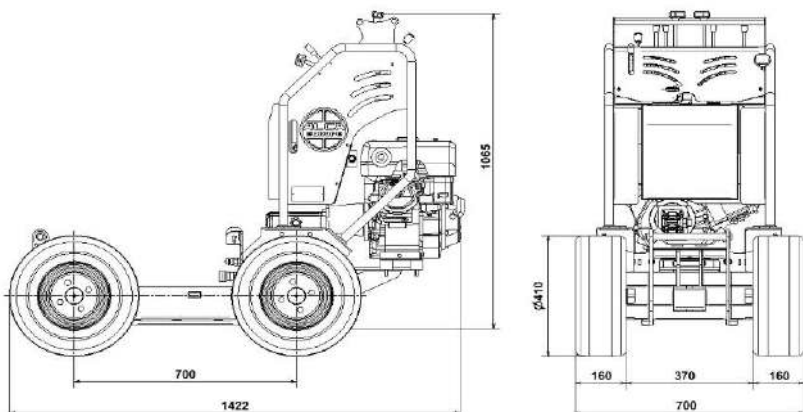

In order to improve the product, Alca Europe reserves the right to modify the characteristics without prior notice.

information



Created to meet the need to move beehives and honey drums in the beekeeping sector, Movebee is the ideal vehicle to help you transport heavy loads. It can be configured with various unloading heights and load capacities.

Thanks to its articulated frame, it can move in confined spaces, and its 4-wheel drive allows it to maintain traction even on the most difficult climbs.

The chassis allows a roll of $\pm 5^\circ$ to tackle potholes and uneven terrain and avoid dangerous oscillations.



TECHNICAL SPECIFICATIONS

Load capacity:	300 kg
Engine:	Honda GX390, 4-stroke single cylinder OHV petrol engine
Max power:	8,7 kW (11,7 HP)
Dimensions:	1535x1050xH1848 mm
Hydraulic pumps:	1 closed loop axial piston pump + 1 gear pump
Transmission:	hydrostatic
Speed:	0-8,5 km/h
Max inclination:	10° - 17%
Empty weight:	~ 600 kg
Tyres dimensions:	21x11.00x10" Tractor
Starting:	electric
Max Lift Height:	2100 mm
Forward/backward tilt of mast:	hydraulic
Hydraulic side shifter:	standard
Hydraulic load clamping:	optional
Hydraulic brake:	standard

DIMENSIONS

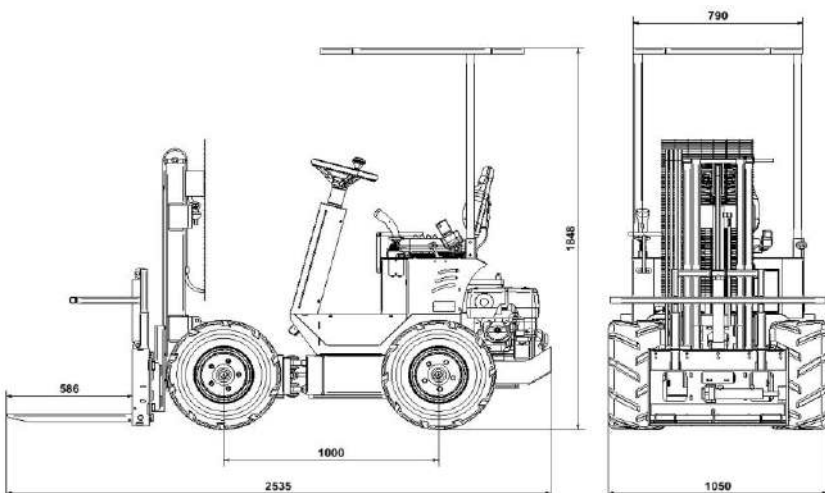

In order to improve the product, Alca Europe reserves the right to modify the characteristics without prior notice.

information





Mini excavators



Micro excavator with fixed turret, 65 cm wide and 190 cm long. It differs from other products in its small size, low centre of gravity and surprising operating capabilities.

Particularly suitable for the wine sector, it assists the operator in removing dead stumps and replacing vines. Thanks to the arm's swing, even the most difficult-to-reach areas can be accessed while remaining in a safe position.

The ES100 can be supplied with various sizes and types of buckets.

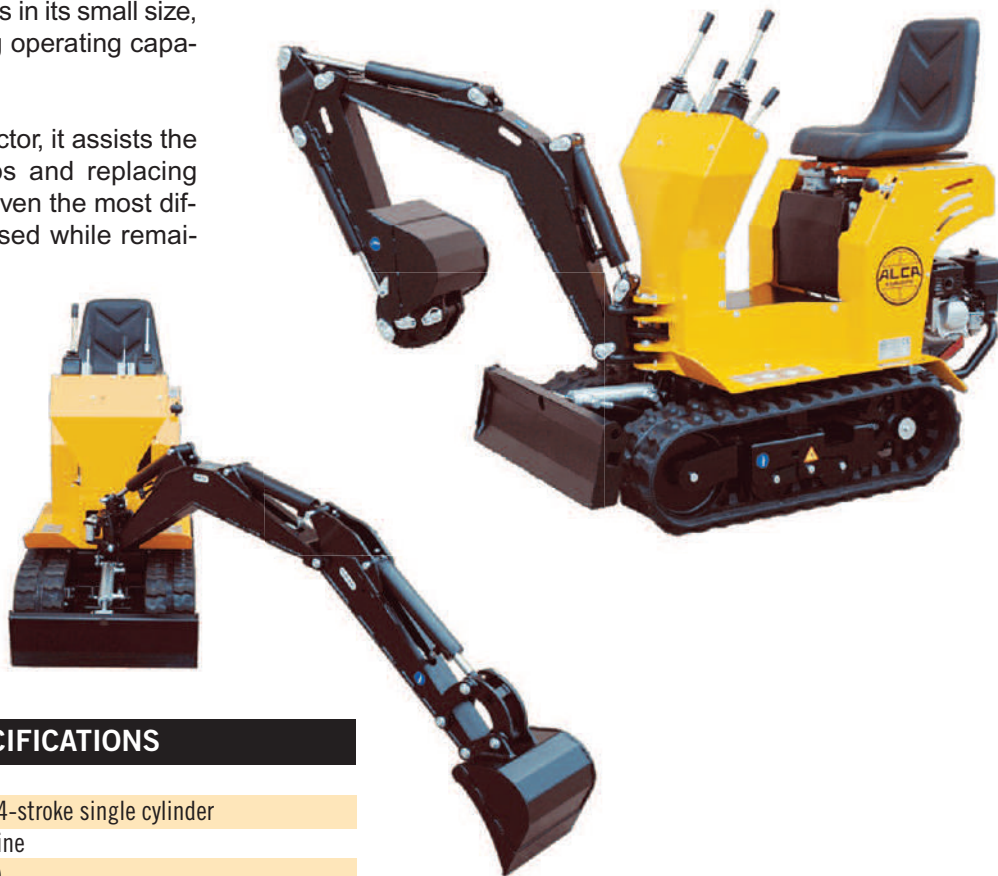

TECHNICAL SPECIFICATIONS

Engine:	Honda GX200, 4-stroke single cylinder OHV petrol engine
Max power:	4,3 kW (5,8 HP)
Dimensions:	1384x650xH1043 mm
Hydraulic pumps:	2 gear pumps
Transmission:	hydraulic
Speed:	0-2,5 km/h
Max inclination:	25° - 46%
Empty weight:	~ 320 kg
Track width:	180 mm
Starting:	manual
Max digging depth:	1000 mm
Boom swing angle:	± 51°
Overcenter valves:	optional

DIMENSIONS

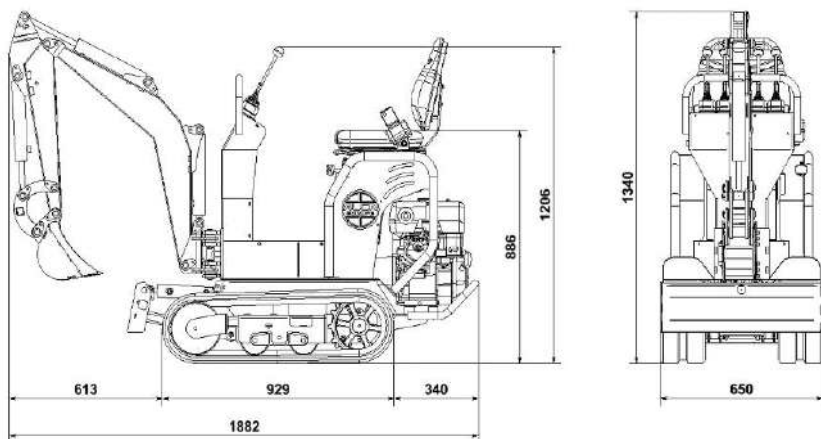

In order to improve the product, Alca Europe reserves the right to modify the characteristics without prior notice.

information





ES150

Alca Europe offers a semi-professional micro excavator, manufactured in Italy.

Ideal for use in confined spaces, inside buildings, in landscaping, agriculture, sports facilities and nurseries.

It is lightweight and compact for transport on category B vehicles, such as vans and trailer trucks. Easy to use, with independent functions for immediate familiarity.

The standard 360° rotating turret ensures considerable ease of use, while the minimal rear dimensions allow it to work in the tightest spaces.

The ES 150 can be configured with an extendable boom and fitted with a hydraulic PTO. It can also be supplied with various sizes and types of buckets.

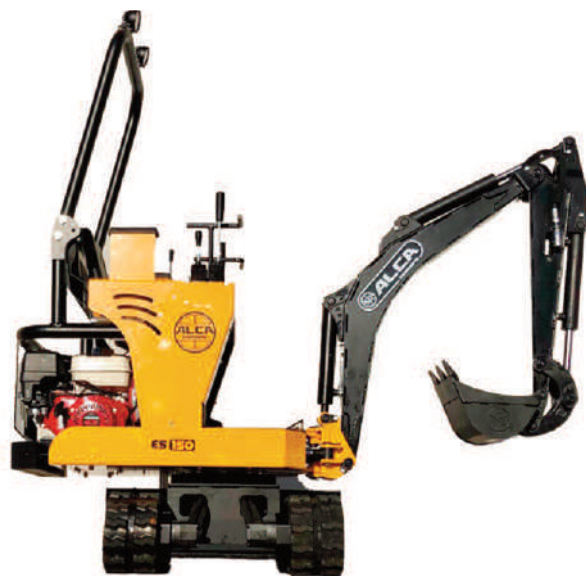

TECHNICAL SPECIFICATIONS

Engine:	Honda GX200, 4-stroke single cylinder OHV petrol engine Honda GX270, 4-stroke single cylinder OHV petrol engine
Max power:	4,3 kW (5,8 HP) - 6,3 Kw (8,4 HP)
Dimensions:	2083x800xH1799 mm
Hydraulic pumps:	2 gear pumps
Transmission:	hydraulic
Speed:	0-2,5 km/h
Max inclination:	25° - 46%
Empty weight:	~ 600 kg
Track width:	180 mm
Starting:	manual / electric optional
Max digging depth:	1500 mm
Swing ring:	standard
Boom swing angle:	optional
Overcenter valves:	standard

DIMENSIONS

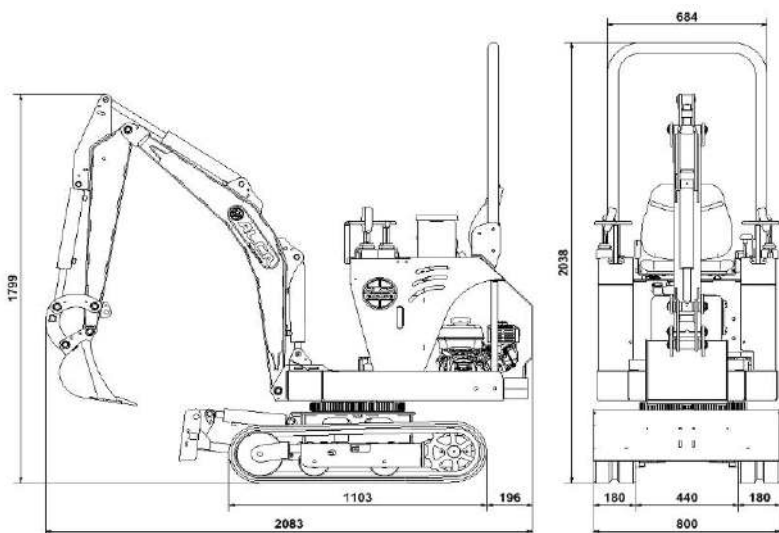

In order to improve the product, Alca Europe reserves the right to modify the characteristics without prior notice.

information



Small tractors and tracked carries



**Easy to handle
and multifunctional**

The TR 20 is a hydrostatic petrol lawn tractor that can be used in any context thanks to its compact size (68 cm wide and 170 cm long).

It is controlled by a joystick and equipped with a hydraulic PTO and other hydraulic lines to operate all the accessories the operator needs.

It is also equipped with front and rear mechanical PTOs, both driven by a belt transmission.



TECHNICAL SPECIFICATIONS

Engine:	Honda GX630, 4-stroke 2-cylinder OHV petrol engine
Max power:	15,5 kW (20,8 HP)
Engine cooling:	forced air
Dimensions:	1704x680xH1306 mm
Hydraulic pumps:	2 closed loop axial piston pump + 2 gear pump
Transmission:	hydrostatic
Speed:	0 - 6,6 km/h
Max inclination:	25° - 46%
Empty weight:	~ 500 kg
Track width:	180 mm
PTO hydraulic:	28 L/min
PTO front mechanical:	1000 RPM anticlockwise
PTO rear mechanical:	540 RPM clockwise
PTO type:	1" 3/8 Z6 - ISO 500
Roll-bar:	standard

DIMENSIONS

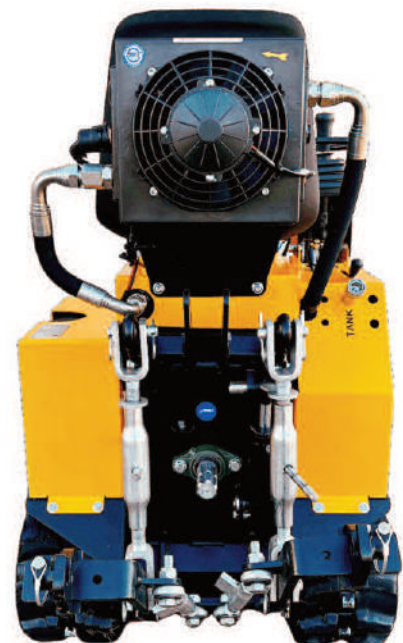
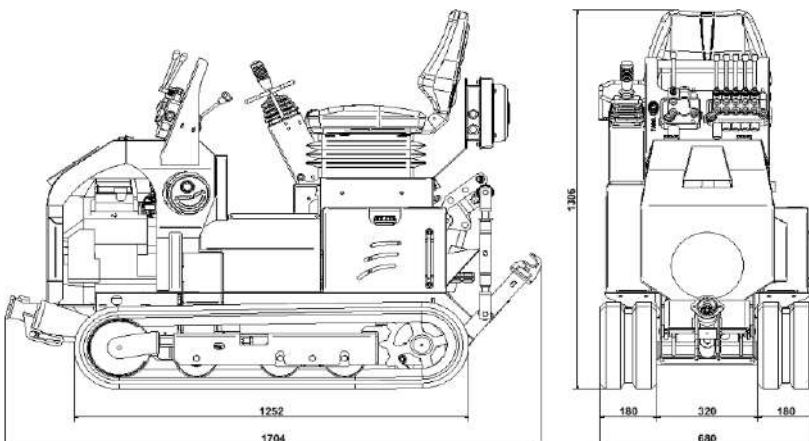

In order to improve the product, Alca Europe reserves the right to modify the characteristics without prior notice.

information



The TR 23 hydrostatic tracked tractor is equipped with a diesel engine.

The tracked undercarriage turns on itself and reduces the turning radius to zero, allowing it to work in the tightest spaces.

Equipped with hydraulic PTO and front and rear mechanical PTO, it can be used with a wide range of accessories.

The comfort of the spring-loaded seat and the simple manoeuvrability of the joystick make the TR 23 an essential ally in everyday work.



TECHNICAL SPECIFICATIONS

Engine:	Yanmar 3TNV70, 4-stroke 3-cylinder diesel engine
Max power:	17 kW (22,7 HP)
Engine cooling:	liquid
Dimensions:	1934x680xH1826 mm
Hydraulic pumps:	2 closed loop axial piston pump + 2 gear pump
Transmission:	hydrostatic
Speed:	0 - 6,6 km/h
Max inclination:	25° - 46%
Empty weight:	~ 600 kg
Track width:	180 mm
PTO hydraulic:	28 L/min
PTO front mechanical:	1000 RPM anticlockwise
PTO rear mechanical:	540 RPM clockwise
PTO type:	1" 3/8 Z6 - ISO 500
Roll-bar:	standard

DIMENSIONS

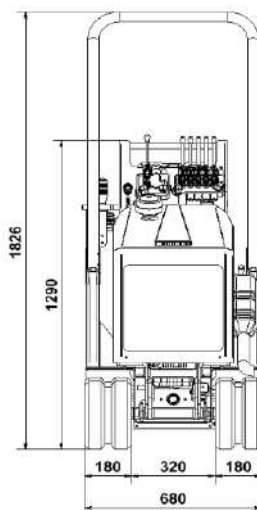
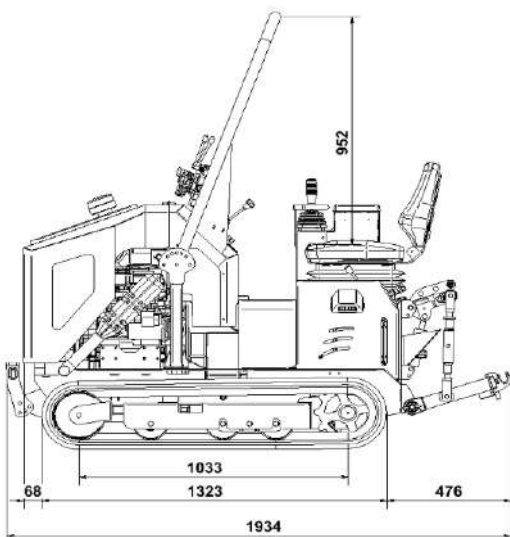

In order to improve the product, Alca Europe reserves the right to modify the characteristics without prior notice.

information



The TR 25's hybrid traction system guarantees the operator stable track thrust and precise hydraulic wheel steering.

The joystick can be used to electrically operate the differential, hydraulic lifts, hydraulic PTO and both front and rear mechanical PTOs.



In addition, the mechanical gearbox ensures higher quality work in the field.



TECHNICAL SPECIFICATIONS

Engine:	Yanmar 3TNV76,4-stroke 3-cylinder diesel engine
Max power:	18,5 kW (24,8 HP)
Engine cooling:	liquid
Dimensions:	2212x690xH1903 mm
Hydraulic pumps:	1 closed loop axial piston pump + 2 gear pump
Transmission:	hydrostatic
Speed:	0 - 8,5, km/h
Max inclination:	25° - 46%
Empty weight:	~ 750 kg
Track width:	180 mm
PTO hydraulic:	28 L/min
PTO front mechanical:	1000 RPM clockwise
PTO rear mechanical:	540 RPM clockwise
PTO type:	1" 3/8 Z6 - ISO 500
Roll-bar:	standard



DIMENSIONS

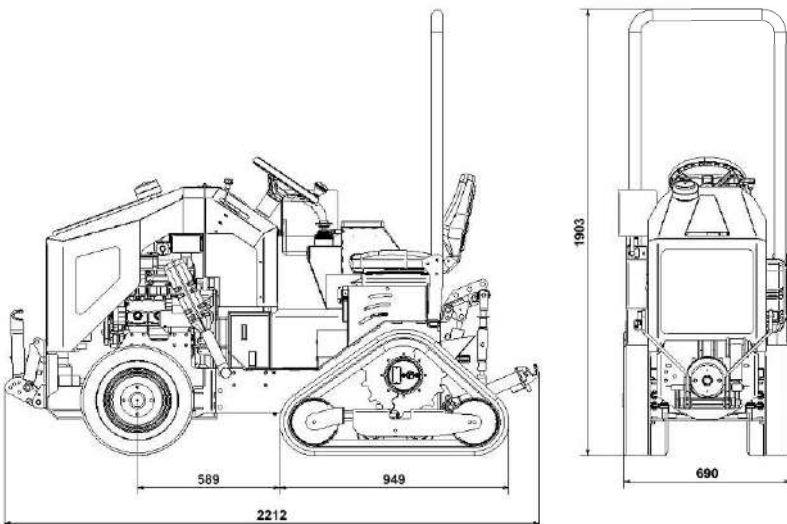

In order to improve the product, Alca Europe reserves the right to modify the characteristics without prior notice.

information



This is the smallest of the tracked carries in the Alca Europe range, complete with slope valves, hydraulic motors and hydraulic PTO.

It stands out for its ease of use and lightness combined with stability and solidity.

Ideal for use in the wine industry.



TECHNICAL SPECIFICATIONS

Operating capacity:	600 kg
Engine:	Honda GX270, 4-stroke single cylinder OHV petrol engine
Max power:	6,3 kW (8,4 HP)
Dimensions:	1498x650xH1215 mm
Hydraulic pumps:	3 gear pumps
Transmission:	hydraulic
Speed:	2 speed: 0-3,2 km/h ; 0-5 km/h
Max inclination:	25° - 46%
Empty weight:	~ 350 kg
Track width:	180 mm
Starting:	manual - electric optional
Overcenter valves:	standard
PTO hydraulic:	14 L/min

DIMENSIONS

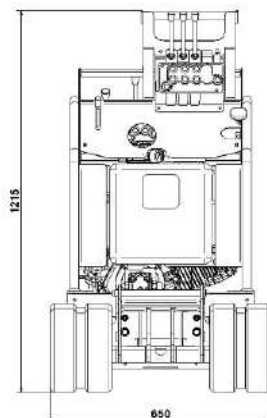
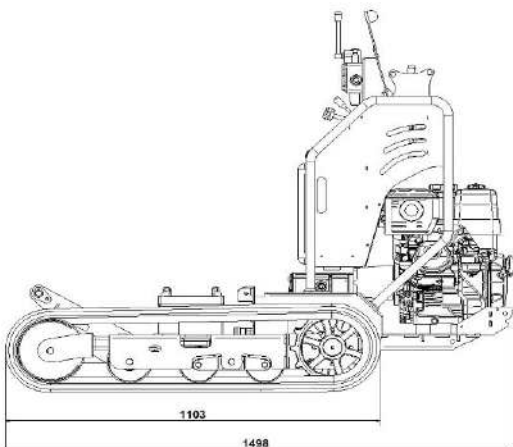

In order to improve the product, Alca Europe reserves the right to modify the characteristics without prior notice.

information



This tracked carries is powered by a 22 hp petrol engine.

Thanks to its hydrostatic transmission, it guarantees constant and precise work throughout the entire route it covers.

It is equipped with a hydraulic PTO and distributor to handle different uses.



TECHNICAL SPECIFICATIONS

Engine:	Honda GX690, 4-stroke 2-cylinder petrol engine
Max power:	16,5 kW (22,1 HP)
Engine cooling:	forced air
Dimensions:	1564x670xH1450 mm
Hydraulic pumps:	2 closed loop axial piston pump + 2 gear pump
Transmission:	hydrostatic
Speed:	0 - 6,8 km/h
Max inclination:	25° - 46%
Empty weight:	~ 430 kg
Track width:	180 mm
PTO hydraulic:	28 L/min

DIMENSIONS

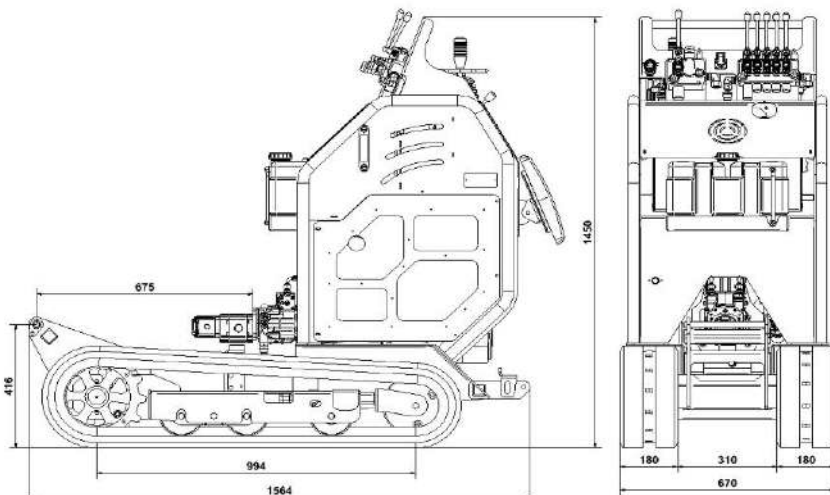

In order to improve the product, Alca Europe reserves the right to modify the characteristics without prior notice.

information



The length of the chassis sets this tracked carries apart and guarantees unique stability.

Equipped with a 25 hp diesel engine, hydraulic PTO and hydrostatic transmission, the VITI 25 allows the operator to tackle slopes of up to 45% and turn easily in tight spaces.



TECHNICAL SPECIFICATIONS

Engine:	Yanmar 3TNV76, 4-stroke 3-cylinder diesel engine
Max power:	18,5 kW (24,8 HP)
Engine cooling:	liquid
Dimensions:	1708x670xH1475 mm
Hydraulic pumps:	2 closed loop axial piston pump + 2 gear pump
Transmission:	hydrostatic
Speed:	0 - 6,9 km/h
Max inclination:	25° - 46%
Empty weight:	~ 550 kg
Track width:	180 mm
PTO hydraulic:	33 L/min

DIMENSIONS

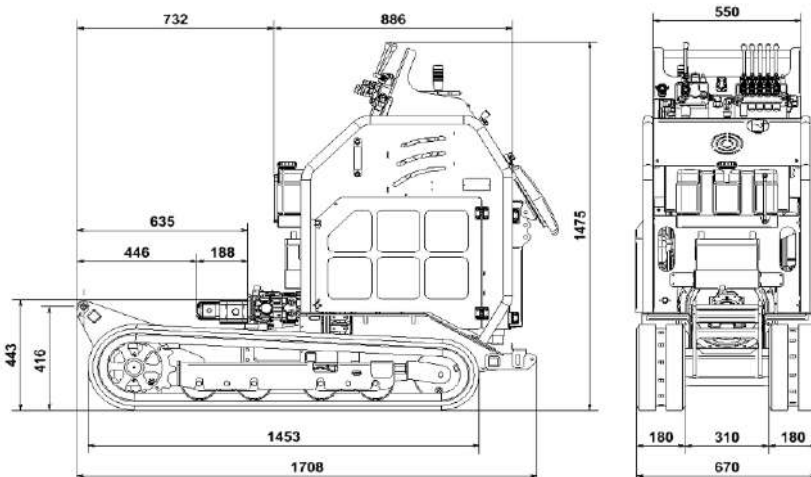

In order to improve the product, Alca Europe reserves the right to modify the characteristics without prior notice.

information



The most professional tracked carries in the range. It is equipped with a 38hp diesel engine, hydraulic PTO and reversible joystick.

These features allow you to work from uphill to downhill and vice versa without having to rotate the machine, and also offer the possibility of moving at different speeds, up to over 7km/h.

All operations can be carried out in extreme comfort thanks to the armrest and legrest cushions.



TECHNICAL SPECIFICATIONS

Engine:	Yanmar 3TNV88, 4-stroke 3-cylinder diesel engine
Max power:	27,5 kW (37 HP)
Engine cooling:	liquid
Dimensions:	2003x690xH1493 mm
Hydraulic pumps:	2 closed loop axial piston pump + 2 gear pump
Transmission:	hydrostatic
Speed:	2 speed: 0-5 km/h ; 0-7,6 km/h
Max inclination:	25° - 46%
Empty weight:	~ 900 kg
Track width:	180 mm
PTO hydraulic:	40 L/min

DIMENSIONS

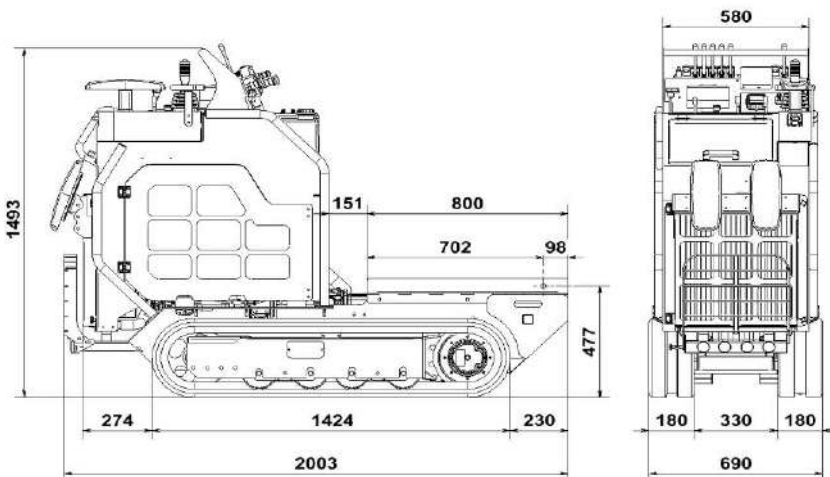

In order to improve the product, Alca Europe reserves the right to modify the characteristics without prior notice.

information



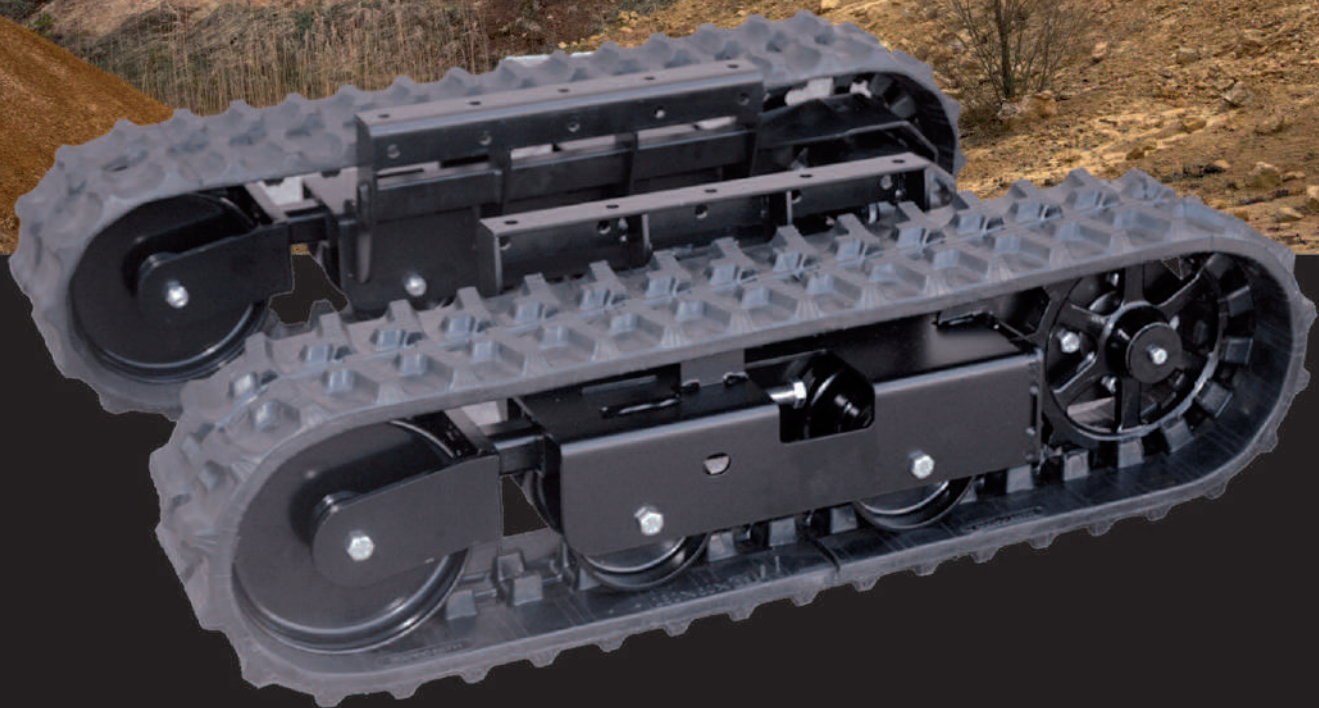

Undercarriages



Under carriages

We offer a range of undercarriages with load capacities from 500 to 1500 kg, adaptable to various uses and terrains.

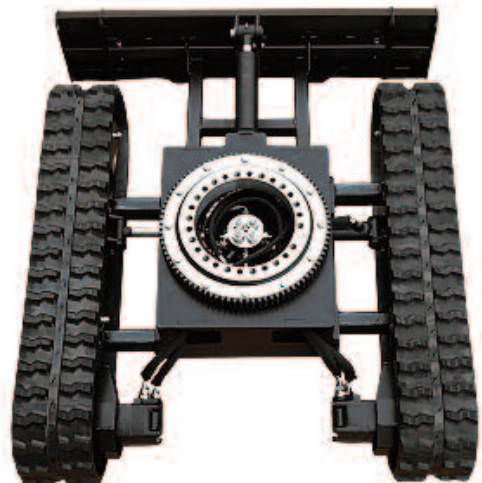
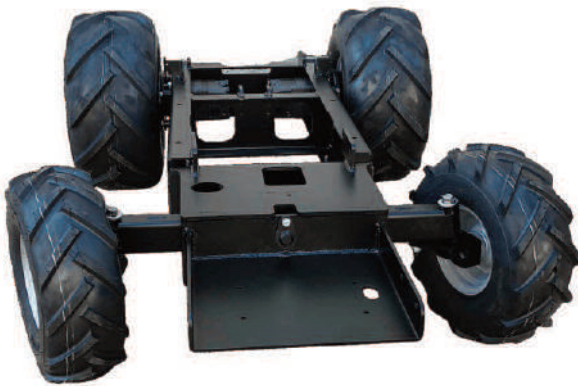
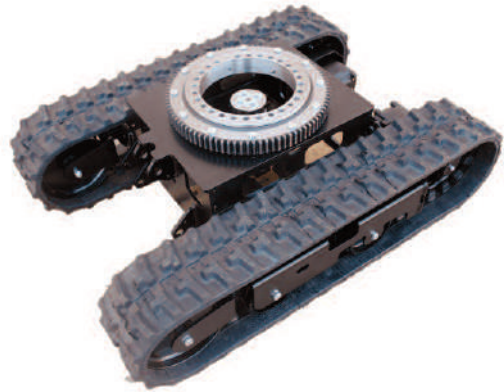
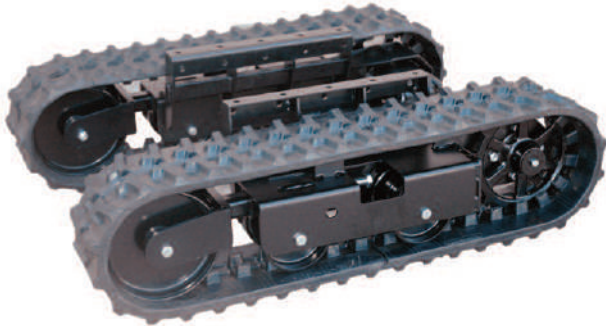

In order to improve the product, Alca Europe reserves the right to modify the characteristics without prior notice.

information

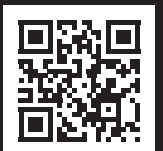



Screens

We offer mobile solutions for crushing and sorting materials, perfect for construction, agricultural and road worksites.

The VG15N double-stage vibrating screen with belt is our flagship product in the fixed screen category.

It allows various types of materials to be separated into different fractions and sizes, with exceptional performance in the electric screen category.

The optimal performance of this machine derives from the unique design of the vibrating structure, equipped with the

latest improvements. This innovative design increases screening performance, efficiency and long-term reliability, with truly long-lasting operation.

The electrical panel also contributes to the safe operation of the machine, its versatility and the measurement of operating time. The VG15N screen offers the best performance on the market: a very wide hopper opening for shovels with a bucket width of 2500 mm and a volume of up to 1.2 m³, offering an unbeatable combination of performance and convenience.

TECHNICAL SPECIFICATIONS

Machine weight:	1500 kg
Type of vibration:	electric
Screening surface:	2000x1500 mm X2 (2X 3.0 m ²)
Screened materials:	2 plus oversize
Loading/unloading blade width:	2500 mm
Power:	1.1 kW - 380V/220V
Double level	
Load volume:	1-1.2 m ³
volume of material processed:	50-80 t/h

DIMENSIONS

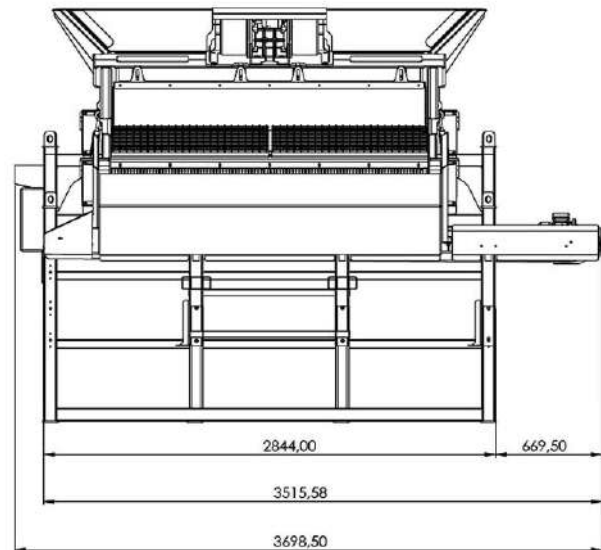
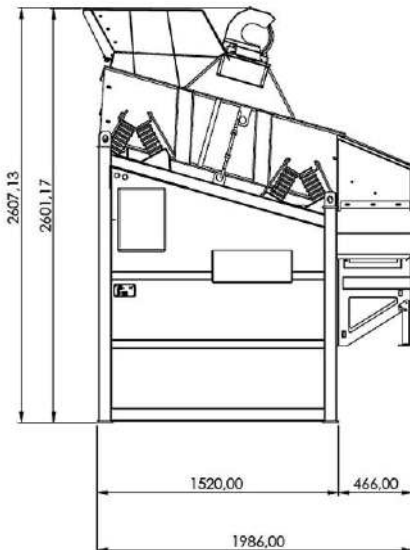

In order to improve the product, Alca Europe reserves the right to modify the characteristics without prior notice.

information

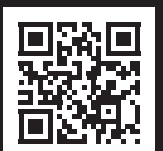



Via dell'Artigianato 14/c - 36048 - Barbarano Mossano - VICENZA - ITALIA

Telefono: +39 0444 183 8315 - info@alcaeuropa.com

www.alcaeuropa.com

